

NOTE- PERFORMANCE AS PER ISO 9906 GRADE-2B

PERFORMANCE CURVE OF 8SW16L @980 R.P.M

8SW16L/X/601556

FISHER PUMP

SW RANGE

MODEL 8SW16L	WORKING PRESS.	12 bar
SIZE 250x200-400	TEST PRESS.	18 bar
TYPE-DRY PIT NON-CLOG SEWAGE PUMP		
MAX. SPHERE SIZE - 75MM	SPEED	980 rpm

SHADED REGION ON THE H-Q CURVE REPRESENTS OPTIMUM SELECTION ZONE

PUMP PERFORMANCE CHARACTERISTICS COMPUTED BASED ON CLEAN COLD WATER S.G 1.0

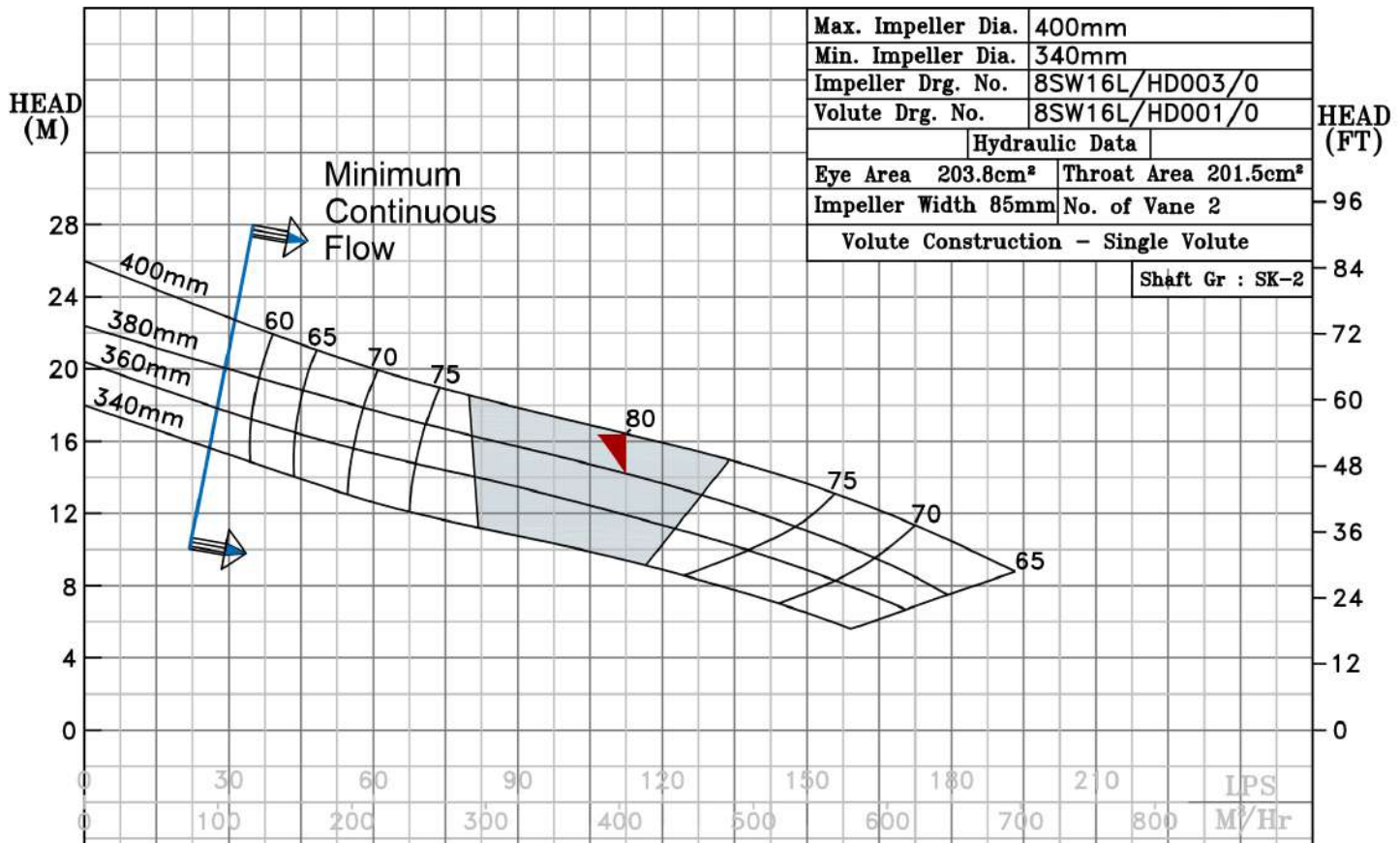

B.E.P Flow	406.6 M³/Hr.
B.E.P Head	16 M
Speed	980 R.P.M
Ns	: 2126 US UNITS

NPSHr	
(M)	(FT)
5	-15
4	-12
3	-9
2	-6

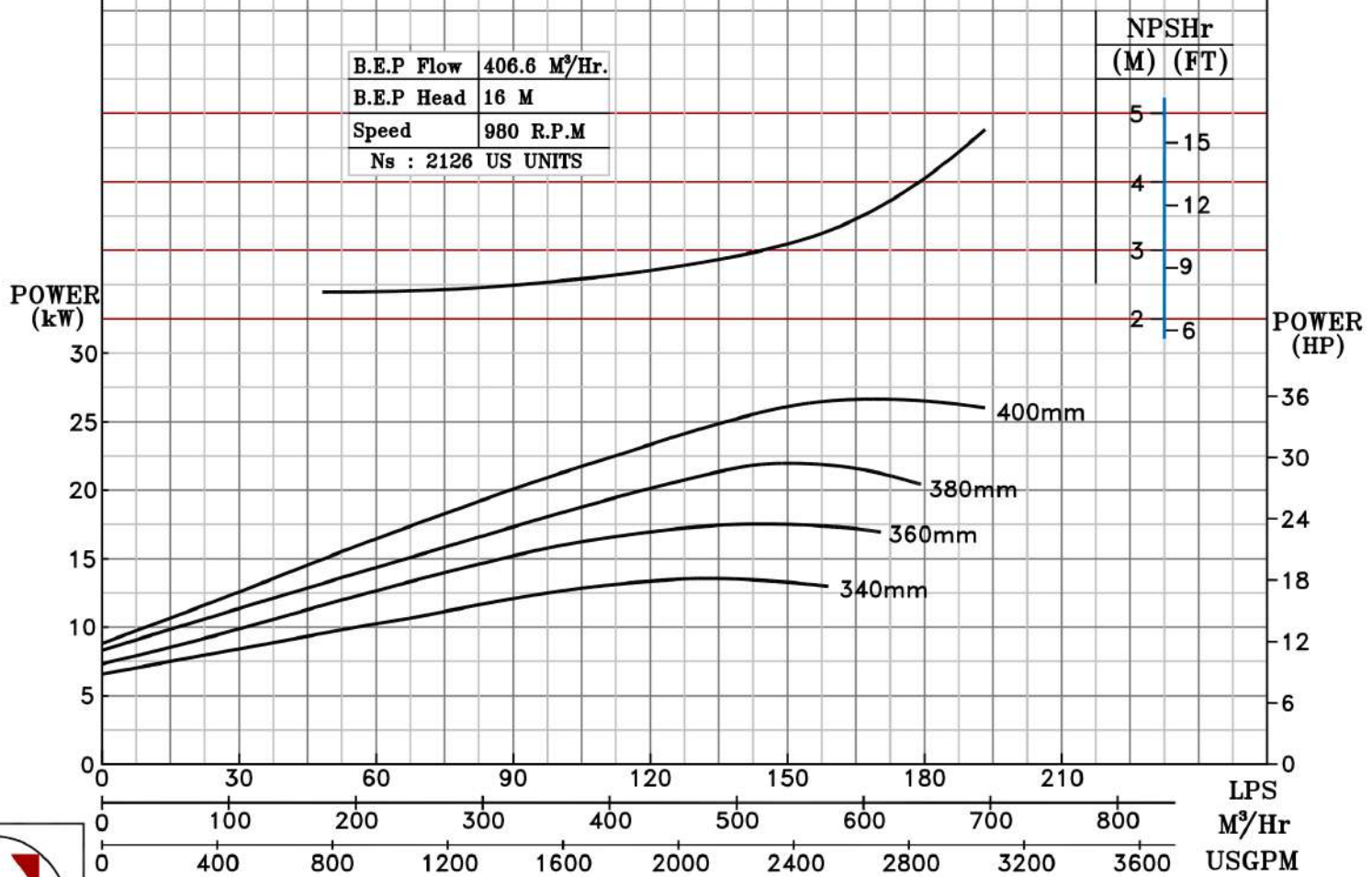

980 RPM