

NOTE- PERFORMANCE AS PER ISO 9906 GRADE-2B

PERFORMANCE CURVE OF 8SW18 @1480 R.P.M		8SW18/X/601754	
FISHER PUMP	MODEL 8SW18	WORKING PRESS.	12 bar
	SIZE 250x200-451	TEST PRESS.	18 bar
	SW RANGE	TYPE-DRY PIT NON-CLOG SEWAGE PUMP	
	SPHERE SIZE - 75 MM	SPEED 1480 rpm	

SHADED REGION ON THE H-Q CURVE REPRESENTS OPTIMUM SELECTION ZONE
 PUMP PERFORMANCE CHARACTERISTICS COMPUTED BASED ON CLEAN COLD WATER S.G 1.0

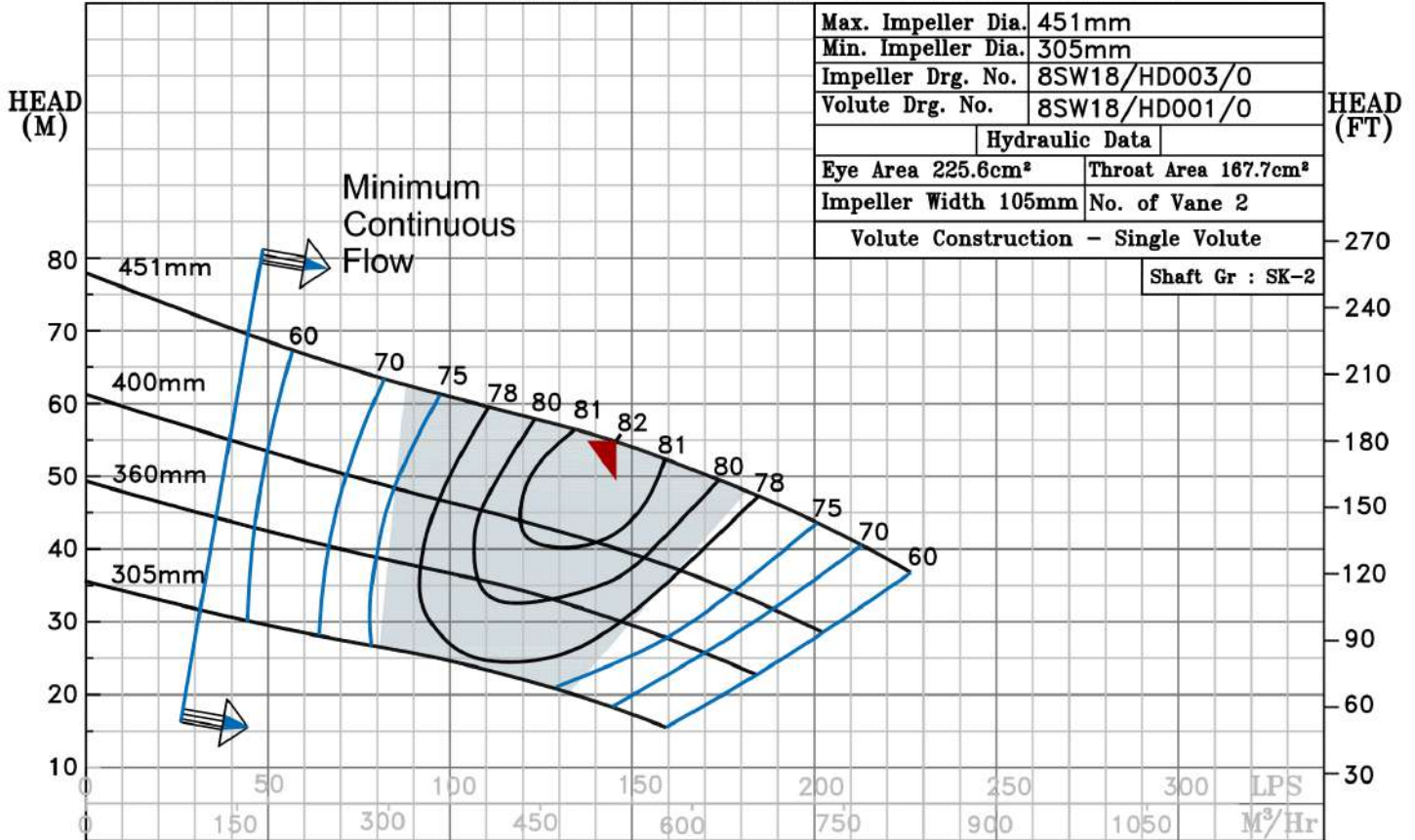

Max. Impeller Dia.	451mm
Min. Impeller Dia.	305mm
Impeller Drg. No.	8SW18/HD003/0
Volute Drg. No.	8SW18/HD001/0
Hydraulic Data	
Eye Area 225.6cm²	Throat Area 167.7cm²
Impeller Width 105mm	No. of Vane 2
Volute Construction - Single Volute	
Shaft Gr : SK-2	

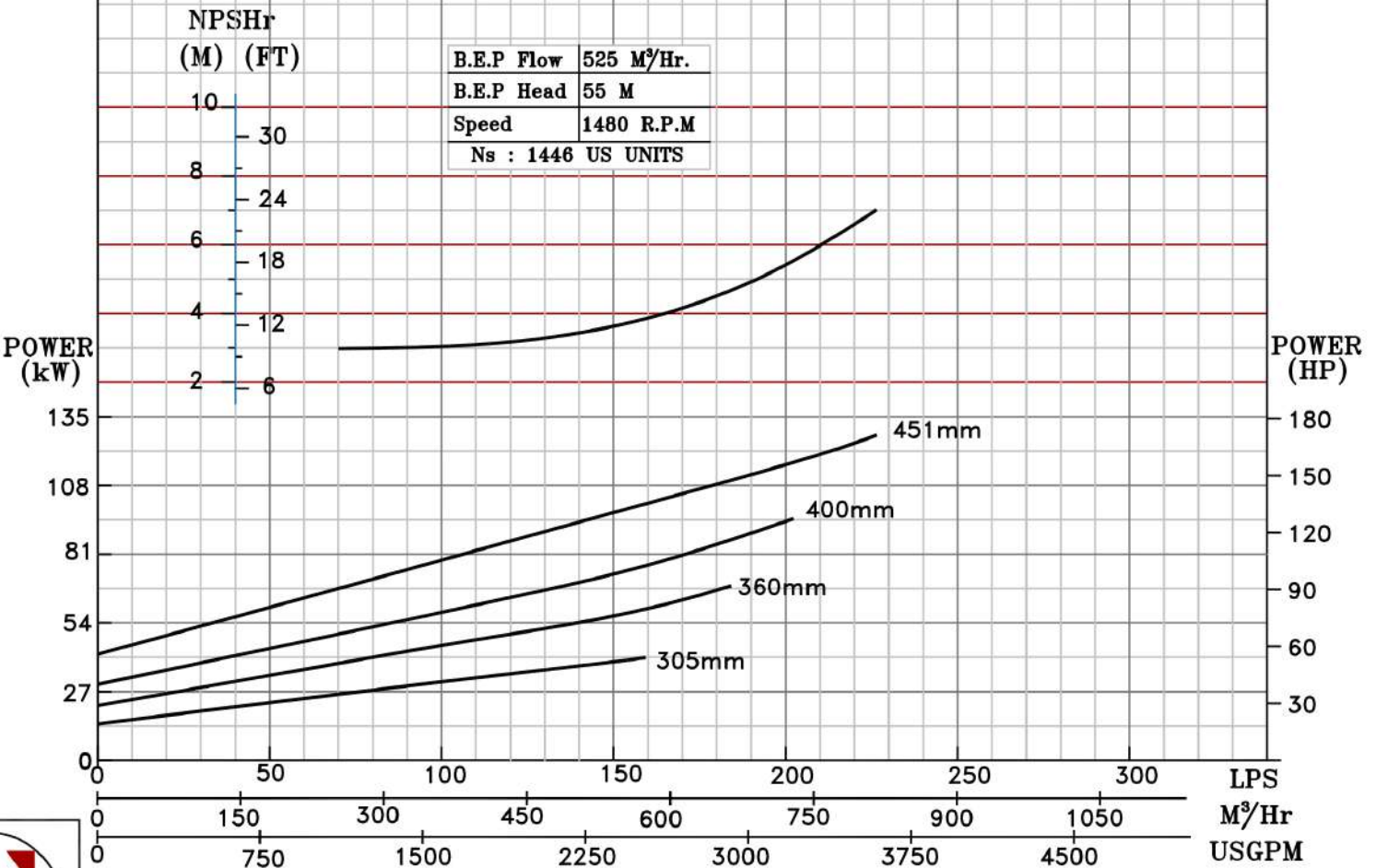

1480 RPM