

PUMP MODEL - 4HF10H

GENERAL ARRANGEMENT DRAWING FOR SINGLE STAGE AXIALLY SPLIT CASE PUMP MODEL - 4HF10H

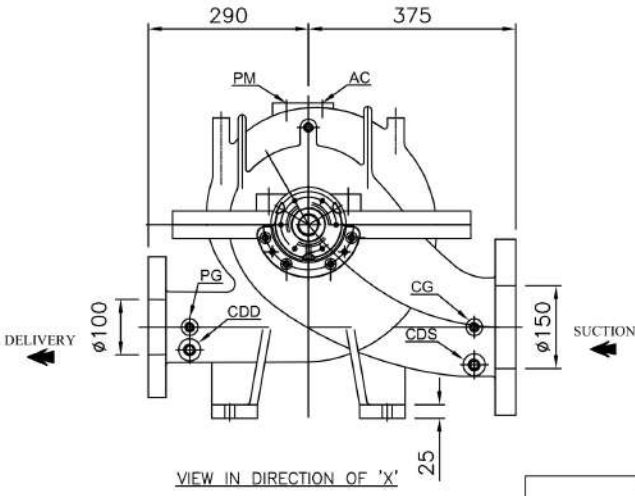

CLOCK-WISE ROTATION
LOOKING FROM DRIVE END

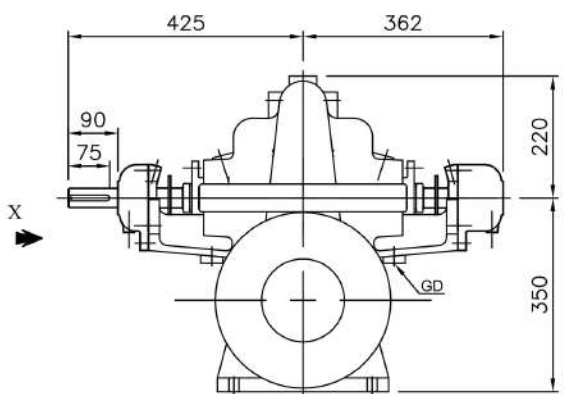
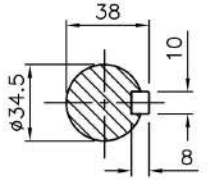

SCALE - 4:1
SHAFT DETAIL AT
COUPLING END

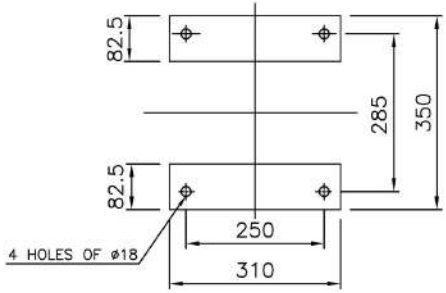

PLAN OF PUMP FEET

ALL DIMENSIONS ARE IN MM.
APPROX. NETT WEIGHT - 251kg.

CONNECTIONS		
ITEM	DESCRIPTION	SIZE (NPT)
GD	GLAND DRAIN	1/2"
CG	COMP. GAUGE FOR SUCTION	3/8"
PG	PR. GAUGE FOR DELIVERY	3/8"
AC	AIR COCK	3/8"
PM	PRIMING	1/2"
CDS	CASING DRAIN (SUCT.SIDE)	1/2"
CDD	CASING DRAIN (DELY.SIDE)	1/2"

NOTES:

1. AN ARROW MARK WILL BE ON THE TOP HALF OF THE CASING TO INDICATE THE DIRECTION OF ROTATION
2. COMPOUND GAUGE, DISCHARGE GAUGE, AIR RELEASE VALVE, CIRCULATION RELIEF VALVE (FOR MOTOR ONLY) WILL BE SUPPLIED WITH UL LISTED PUMP

FLANGE STD. - ANSI/ASME B16.1

SUC	ANSI250#FF	12-1/2"	10-5/8"	1-7/16"	12, Ø7/8"	---	---
DEL 100Ø	ANSI250#FF	10"	7-7/8"	1-1/4"	8, Ø7/8"	---	---
	TYPE OF FLANGE	O.D.	P.C.D.	THK MIN	NO & HOLE Ø	RFØ	RF THK RF FLANGE

				FISHER PUMP			
				TITLE-			
				GA DRAWING FOR 4HF10H			REV 0
REV	DESCRIPTION	DRN	CHKD	APPD	HS	DRG. NO. 838GA10YJ	