

PUMP MODEL- 4HF16

GENERAL ARRANGEMENT DRAWING FOR SINGLE STAGE AXIALLY SPLIT CASE PUMP MODEL - 4HF16

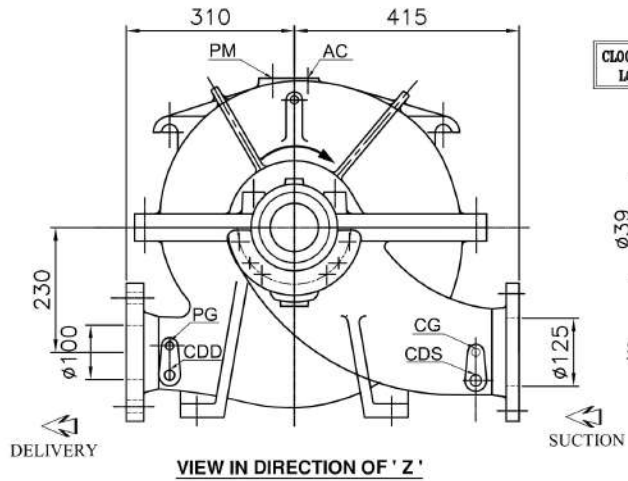

CLOCK-WISE ROTATION
LOOKING FROM DRIVE END

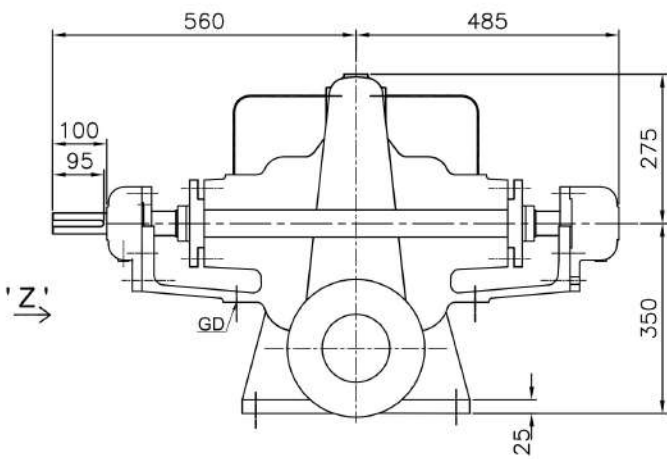
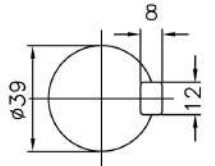

SCALE - 5:1
SHAFT DETAIL AT
COUPLING END

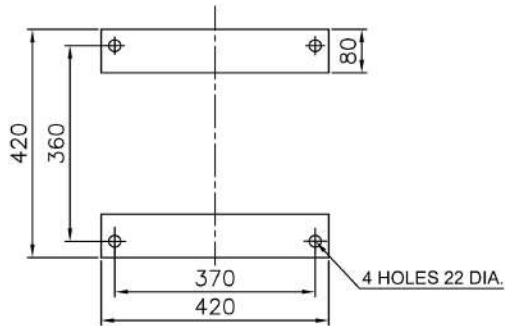

APPROX. NET WEIGHT - 230Kg.
ALL DIMENSIONS ARE IN MM.

CONNECTIONS		
ITEM	DESCRIPTION	SIZE(NPT)
GD	GLAND DRAIN	3/4"
CG	COMPOUND GAUGE FOR SUCTION	3/8"
PG	PRESSURE GAUGE FOR DELIVERY	3/8"
AC	AIR COCK	3/8"
PM	PRIMING	3/4"
CDS	CASING DRAIN(SUCTION SIDE)	1/2"
CDD	CASING DRAIN(DELIVERY SIDE)	1/2"

S	ANSI 125# FF	10"	8-1/2"	15/16"	8, 7/8"	--	--										
D	ANSI 250# FF							10"	7-7/8"	1-1/4"	8, 7/8"	--	--				
REF. NO.	TYPE OF FLANGE.	O.D.	P.C.D.	THK MIN	NO SIZE OF HOLE	RFØ R.F.	RF THK FLANGE	O.D.	P.C.D.	THK MIN	NO SIZE OF HOLE	RFØ R.F.	RF THK FLANGE				
		SUCTION~ 125Ø (5")				DELIVERY~ 100Ø (4")											

FISHER PUMP							SCALE	
TITLE: GA DRG. FOR 4HF16							1:1	
REV	DESCRIPTION	DRN	CHKD	APPD	HS	DRG. NO.	REV	
						PSF/4HF16/GA-01	0	