

PUMP MODEL - 5HF10

GENERAL ARRANGEMENT DRAWING FOR SINGLE STAGE AXIALLY SPLIT CASE PUMP MODEL - 5HF10

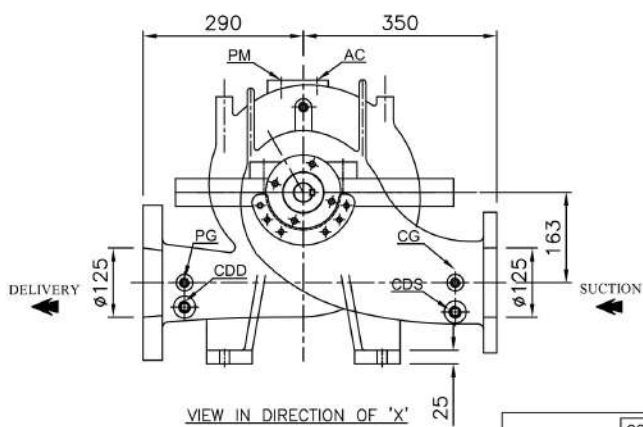

CLOCK-WISE ROTATION
LOOKING FROM DRIVE END

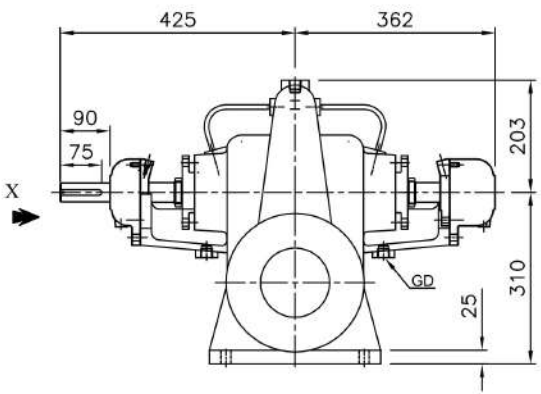
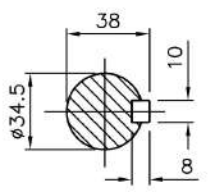

SCALE - 4:1
SHAFT DETAIL AT
COUPLING END

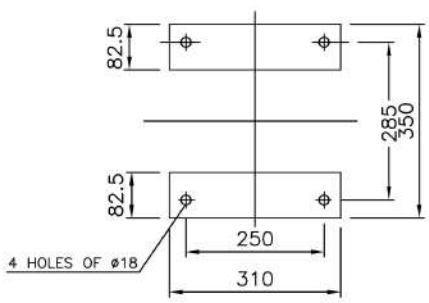

PLAN OF PUMP FEET

ALL DIMENSIONS ARE IN MM.
APPROX. NETT WEIGHT - 205kg.

CONNECTIONS		
ITEM	DESCRIPTION	SIZE (NPT)
GD	GLAND DRAIN	1/2"
CG	COMP. GAUGE FOR SUCTION	3/8"
PG	PR. GAUGE FOR DELIVERY	3/8"
AC	AIR COCK	3/8"
PM	PRIMING	1/2"
CDS	CASING DRAIN (SUCT.SIDE)	1/2"
CDD	CASING DRAIN (DELY.SIDE)	1/2"

NOTES:

1. AN ARROW MARK WILL BE ON THE TOP HALF OF THE CASING TO INDICATE THE DIRECTION OF ROTATION
2. COMPOUND GAUGE, DISCHARGE GAUGE, AIR RELEASE VALVE, CIRCULATION RELIEF VALVE (FOR MOTOR ONLY) WILL BE SUPPLIED WITH UL LISTED PUMP

FLANGE TABLE

S	ANSI 125#FF	10"	8-1/2"	15/16"	8, #7/8"										
D	ANSI 250#FF						11"	9-1/4"	1-3/8"	8, #7/8"					
REF. NO.	TYPE OF FLANGE	O.D.	P.C.D.	THK MIN	NO. SIZE OF HOLE	RF	ØRF. THK RF FLANGE	O.D.	P.C.D.	THK MIN	NO. SIZE OF HOLE	RF	ØRF. THK RF FLANGE		
				SUCTION - 125(5")				DELIVERY - 125(5")							

FISHER PUMP											
TITLE-										SCALE	
GA DRAWING FOR 5HF10										1:1	
DRN	SN	03.02.23								DRG. NO.	
CHKD	TK	03.02.23								836GA10YJ	
APPD	HS	03.02.23								REV	
										0	