

PUMP MODEL - 3HFT11

GENERAL ARRANGEMENT DRAWING FOR TWO STAGE AXIALLY SPLIT-CASE PUMP MODEL - 3HFT11

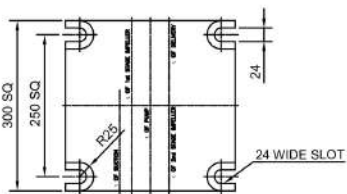
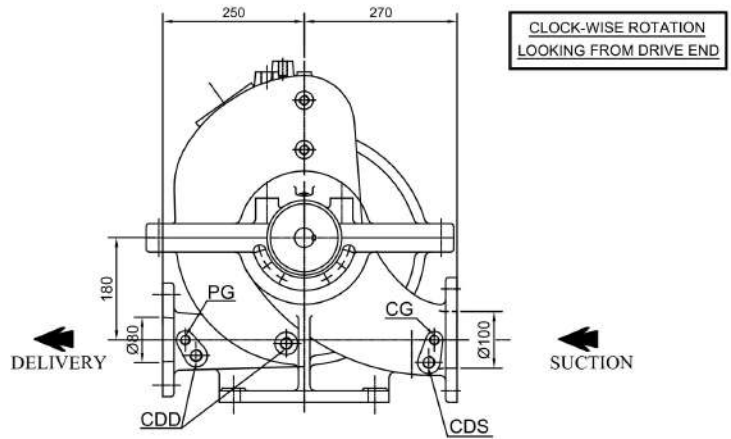
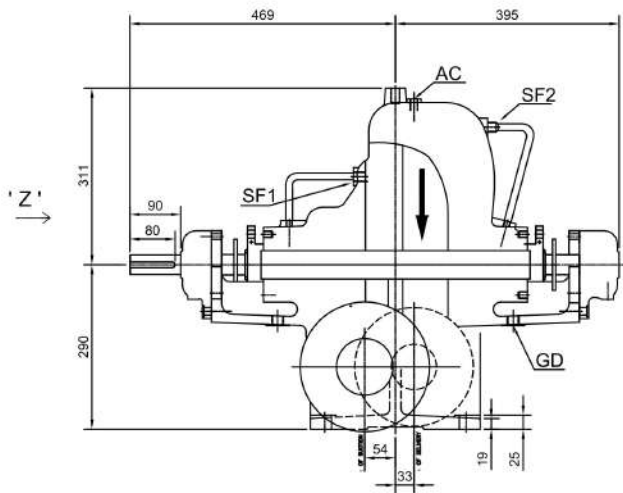

DETAIL OF PUMP FEET

VIEW IN DIRECTION OF ' Z '

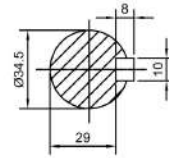

**SCALE-4:1
SHAFT DETAILS
AT COUPLING END**

**APPROX. NETT WEIGHT - 312kg.
ALL DIMENSIONS ARE IN MM.**

CONNECTION		
ITEM	DESCRIPTION	SIZE(NPT)
GD	GLAND DRAIN	1/2"
CG	COMPOUND GAUGE FOR SUCTION	3/8"
PG	PRESSURE GAUGE FOR DELIVERY	3/8"
AC	AIR COCK (SUITS FOR AARV)	1/2"
PM	PRIMING	3/8"
CDS	CASING DRAIN(SUCTION SIDE)	1/2"
CDD	CASING DRAIN(DELIVERY SIDE)	1/2"

S	ANSI#125	9"	7-1/2"	15/16"	8, 3/4"	--	--	--	--
D	ANSI#250	--	--	--	--	8-1/4"	6-5/8"	1-1/8"	8, 7/8"
REF. NO.	TYPE OF FLANGE.	O.D.	P.C.D.	THK MIN	NO SIZE OF HOLE	O.D.	P.C.D.	THK MIN	NO. SIZE OF HOLE
		SUCTION 100Ø				DELIVERY 80Ø			

FISHER PUMP						
TITLE GA DRAWING FOR 3HFT11						
DRN	AD	13.02.15	DRG. NO.	3HFT11/GA-01/0		REV 0
CHKD	ST	13.02.15	IDENTIFICATION NO.	9023530		
APPD	HS	13.02.15				
REV	DESCRIPTION	DRN	CHKD	APPD	DATE	