

PUMP MODEL - 10HF22/MK1

GENERAL ARRANGEMENT DRAWING FOR SINGLE STAGE AXIALLY SPLIT CASE PUMP MODEL - 10HF22/MK1

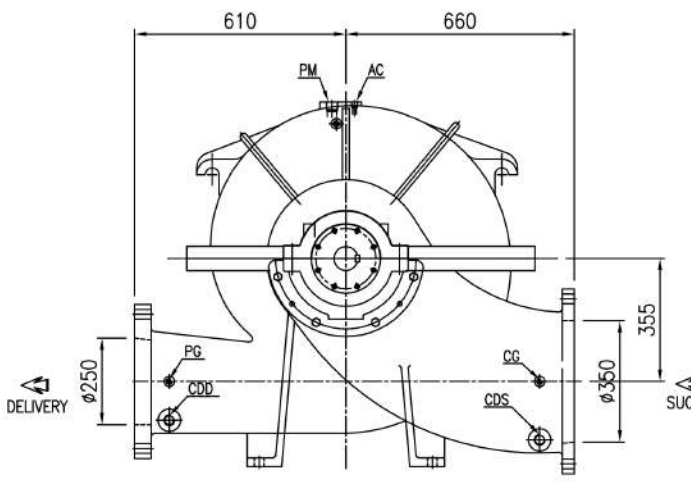

CLOCK-WISE ROTATION  
LOOKING FROM DRIVE END

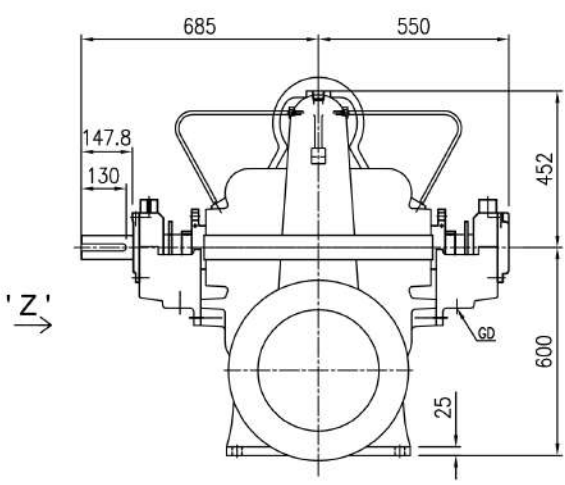
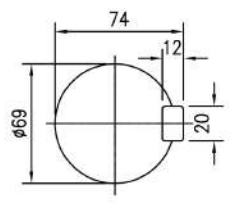

SCALE - 5:1  
SHAFT DETAIL AT  
COUPLING END

VIEW IN DIRECTION OF 'Z'

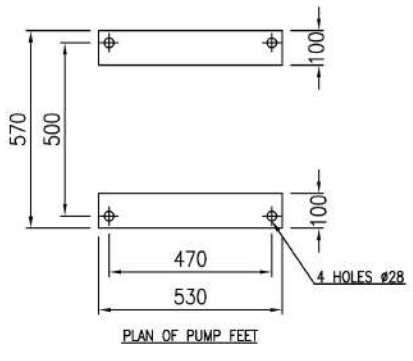

APPROX. NET WEIGHT - 1100kg.  
ALL DIMENSIONS ARE IN MM.

CONNECTIONS		
ITEM	DESCRIPTION	SIZE(NPT)
GD	GLAND DRAIN	1"
CG	COMPOUND GAUGE FOR SUCTION	3/8"
PG	PRESSURE GAUGE FOR DELIVERY	3/8"
AC	AIR COCK	3/8"
PM	PRIMING	1-1/2"
CDS	CASING DRAIN(SUCTION SIDE)	1"
CDD	CASING DRAIN(DELIVERY SIDE)	1"

\* GAUGE CONNECTIONS SHOWN AND TAPPED ONLY  
OTHER CONNECTIONS INDICATED BY THE CUSTOMER.

PROJECT NAME-	JOB NO.-
<b>FISHER PUMP</b>	
TITLE- GA DRG. FOR 10HF22/MK1	
DRN	18.08.14
CHKD	18.08.14
APPD	18.08.14
DRG. NO.	PSF/10HF22/MK1/GA-01
SCALE	1:1
REV	0

S	ANSI#250	23'	20-1/4"	2-1/8"	20, #1-1/4"								
D	ANSI#250						17-1/2"	15-1/4"	1-7/8"	16, #1-1/8"			
REF. NO.	TYPE OF FLANGE.	O.D.	P.C.D.	THK MIN	NO SIZE OF HOLE OFF C/L	RFØ	RF THK R.F. FLANGE	O.D.	P.C.D.	THK MIN	NO SIZE OF HOLE OFF C/L	RFØ	RF THK R.F. FLANGE
		SUCTION - Ø350						DELIVERY - Ø250					

REV	DESCRIPTION	DRN	CHKD	DATE