

PUMP MODEL - 3HF12

GENERAL ARRANGEMENT DRAWING FOR SINGLE STAGE AXIALLY SPLIT CASE PUMP MODEL - 3HF12

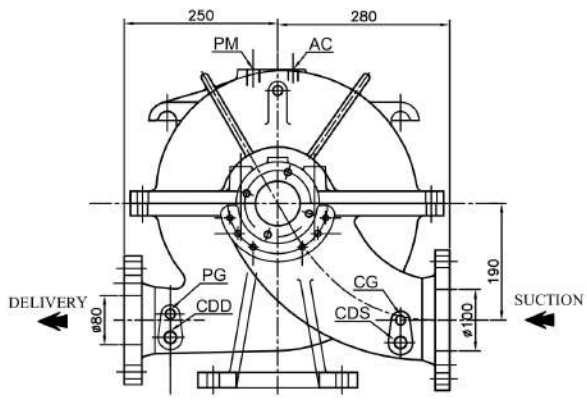

CLOCK-WISE ROTATION
LOOKING FROM DRIVE END

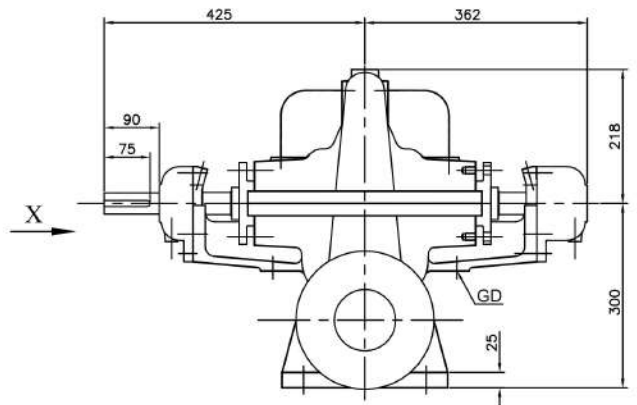
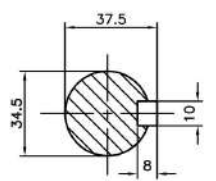

SCALE - 4:1
SHAFT DETAIL AT
COUPLING END

VIEW IN DIRECTION OF ' X '

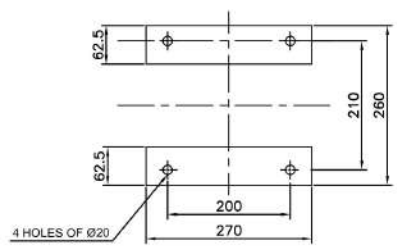

PLAN OF PUMP FEET

APPROX. NETT WEIGHT - 200kg.
ALL DIMENSIONS ARE IN MM.

CONNECTIONS		
ITEM	DESCRIPTION	SIZE (NPT)
GD	GLAND DRAIN	1/2"
CG	COMP. GAUGE FOR SUCTION	3/8"
PG	PR. GAUGE FOR DELIVERY	3/8"
AC	AIR COCK	3/8"
PM	PRIMING	1/2"
CDS	CASING DRAIN (SUCT.SIDE)	1/2"
CDD	CASING DRAIN (DELY.SIDE)	1/2"

S	ANSI#125	9"	7-1/2"	15/16"	8, 3/4"	--	--	--	--
D	ANSI#250	--	--	--	--	8-1/4"	6-5/8"	1-1/8"	8, 7/8"
REF. NO.	TYPE OF FLANGE.	O.D.	P.C.D.	THK MIN	NO SIZE OF HOLE	O.D.	P.C.D.	THK MIN	NO. SIZE OF HOLE
		SUCTION 100Ø				DELIVERY 80Ø			

1	NEW CASING GA	AD	ST	17.05.18
REV	DESCRIPTION	DRN	CHKD	DATE

FISHER PUMP					
TITLE GA DRAWING FOR 3HF12					
DRN	AD	11.04.15	DRG. NO.	PSF/3HF12/GA-01(0)/0	SCALE
CHKD	SP	11.04.15			1:1
APPD	HS	11.04.15	8012640-1	REV	0