

PUMP MODEL - 8HF20

GENERAL ARRANGEMENT DRAWING FOR SINGLE STAGE AXIALLY SPLIT CASE PUMP MODEL - 8HF20

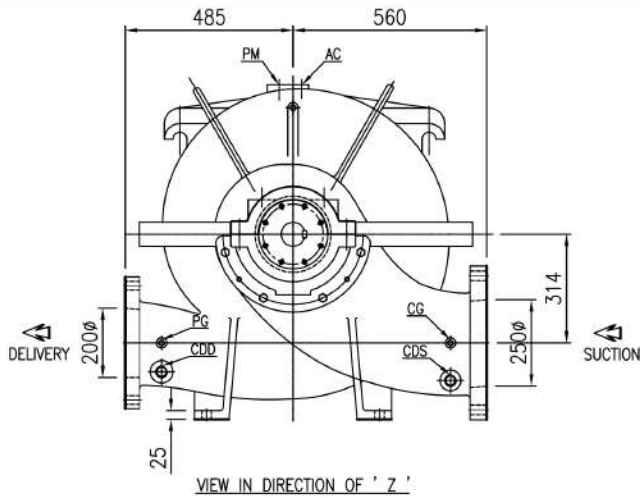

CLOCK-WISE ROTATION
LOOKING FROM DRIVE END

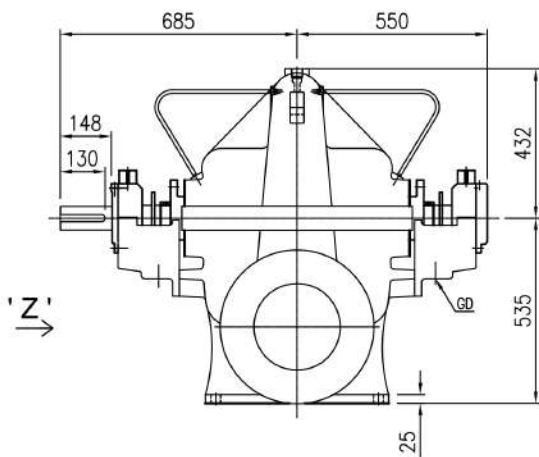
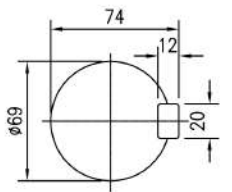

SCALE - 5:1
SHAFT DETAIL AT
COUPLING END

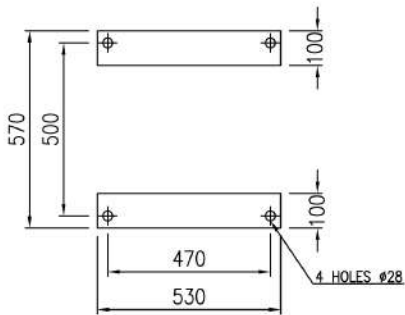

PLAN OF PUMP FEET

APPROX. NET WEIGHT - 860kg.
ALL DIMENSIONS ARE IN MM.

CONNECTIONS		
ITEM	DESCRIPTION	SIZE(NPT)
GD	GLAND DRAIN	1"
CG	COMPOUND GAUGE FOR SUCTION	3/8"
PG	PRESSURE GAUGE FOR DELIVERY	3/8"
AC	AIR COCK	3/8"
PM	PRIMING	1-1/2"
CDS	CASING DRAIN(SUCTION SIDE)	1"
CDD	CASING DRAIN(DELIVERY SIDE)	1"

** GAUGE CONNECTIONS DRILLED AND TAPPED ONLY
YOUR RESPONSIBILITY PROVIDED BY THE CUSTOMER

S	ANSI#250	17-1/2"	15-1/4"	1-7/8"	16, Ø1-1/8"										
D	ANSI#250							15"	13"	1-5/8"	12, Ø1"				
REF. NO.	TYPE OF FLANGE.	O.D.	P.C.D.	THK MIN	NO SIZE OF HOLE OFF C/L	RFØ	RF THK R.F. FLANGE	O.D.	P.C.D.	THK MIN	NO SIZE OF HOLE OFF C/L	RFØ	RF THK R.F. FLANGE		
		SUCTION - Ø250				DELIVERY - Ø200									

REV	DESCRIPTION	DRN	CHKD	DATE

PROJECT NAME- _____ JOB NO.- _____

FISHER PUMP

TITLE- **GA DRG. FOR 8HF20**

SCALE 1:1

DRN	AD	18.09.19	DRG. NO. 831GA10Y
CHKD	TK	18.09.19	
APPD	BS	18.09.19	

REV 0