

PUMP MODEL - 8HF20

GENERAL ARRANGEMENT DRAWING FOR SINGLE STAGE AXIALLY SPLIT CASE PUMP M

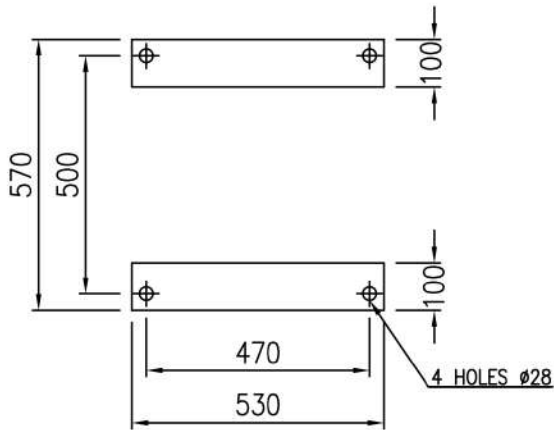
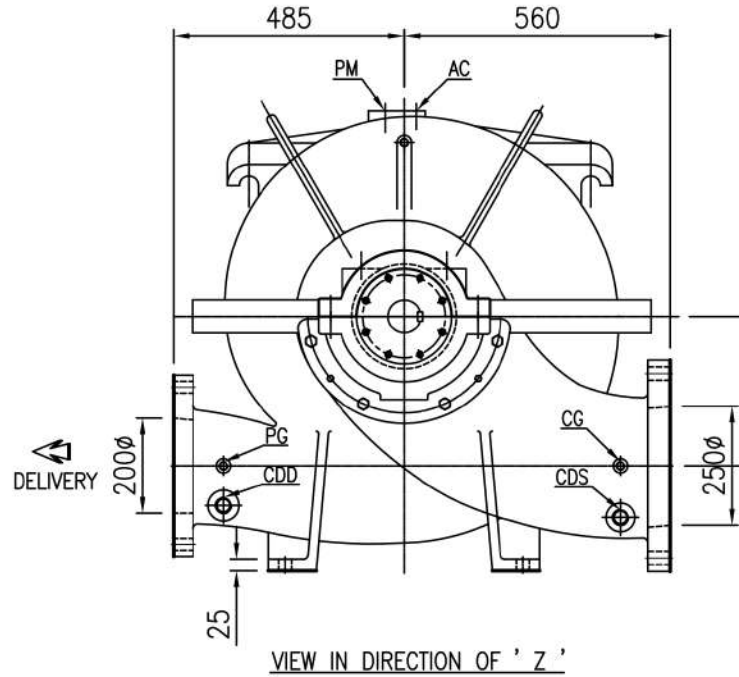
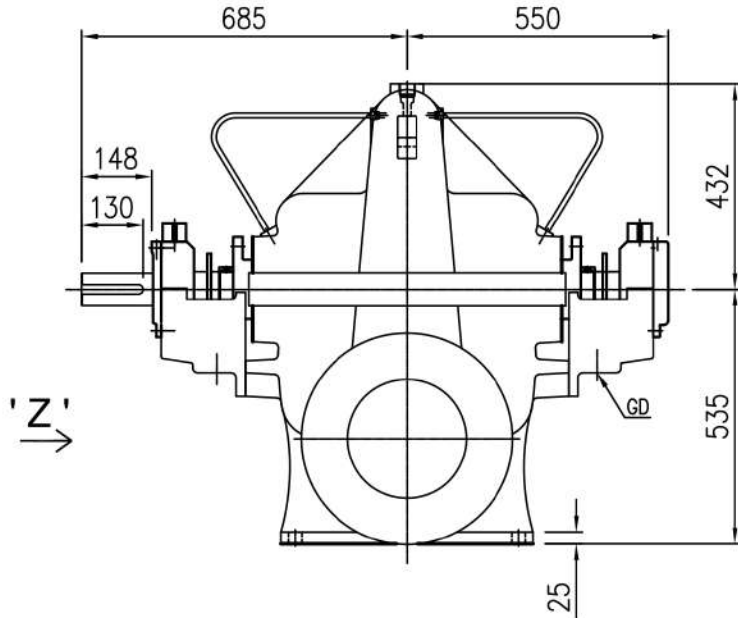

PLAN OF PUMP FEET

APPROX. NET WEIGHT - 860kg
ALL DIMENSIONS ARE IN MM.

FISHER PUMP

S	ANSI#250	17-1/2"	15-1/4"	1-7/8"	16, ø1-1/8"	—	—						
D	ANSI#250							15"	13"	1-5/8"	12, ø1"	—	—
REF. NO.	TYPE OF FLANGE.	O.D.	P.C.D.	THK MIN	NO SIZE OF HOLE OFF C/L	RFø	RF THK R.F. FLANGE	O.D.	P.C.D.	THK MIN	NO SIZE OF HOLE OFF C/L	RFø	RF THK R.F. FLANGE
		SUCTION - ø250						DELIVERY - ø200					

REV	DESCRIPTION	DRN	CHKD