

PUMP MODEL- 6HFTD12S

GENERAL ARRANGEMENT DRAWING FOR TWO STAGE AXIALLY SPLIT-CASE PUMP MODEL - 6HFTD12S

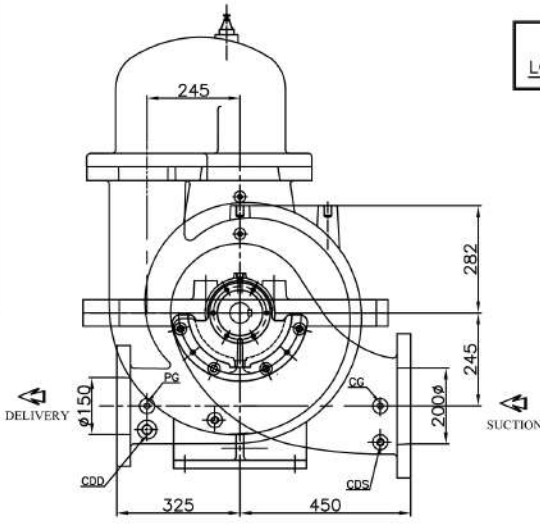

CLOCK WISE ROTATION
LOOKING FROM DRIVE END

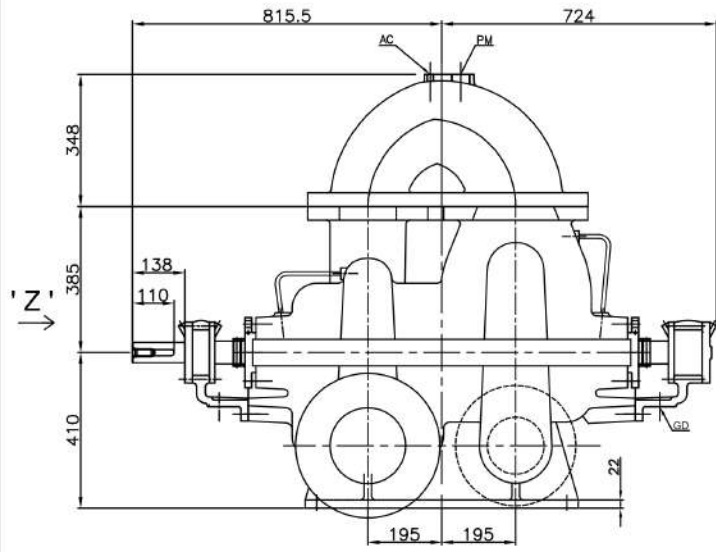
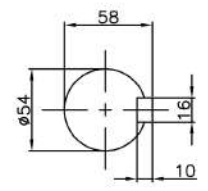

SCALE-4:1
SHAFT DETAILS
AT COUPLING END

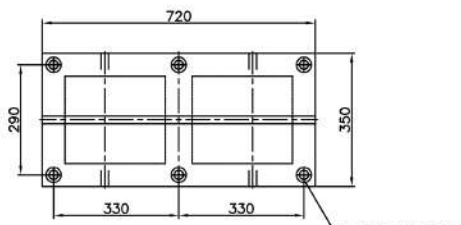

PLAN OF PUMP FEET

6-HOLES, DRILLED 24# & SPOT FACED 40#

APPROX. NETT WEIGHT - 1300kg.
ALL DIMENSIONS ARE IN MM.

CONNECTIONS		
ITEM	DESCRIPTION	SIZE(NPT)
GD	GLAND DRAIN	3/4"
CG	COMPOUND GAUGE FOR SUCTION	3/8"
PG	PRESSURE GAUGE FOR DELIVERY	3/8"
AC	AIR COCK	3/8"
PM	PRIMING	1"
CDS	CASING DRAIN(SUCTION SIDE)	1/2"
CDD	CASING DRAIN(DELIVERY SIDE)	1/2"

REF. NO.	TYPE OF FLANGE	O.D.	P.C.D.	THK MIN	NO. OF HOLES	SIZE OF HOLE	RF	ORF. THK	RF FLANGE	O.D.	P.C.D.	THK MIN	NO. OF HOLES	SIZE OF HOLE	RF	ORF. THK	RF FLANGE
S	ANSI 250	15"	13"	1-5/8"	12	1"											
D	ANSI 250									12-1/2"	10-5/8"	1-7/16"	12	7/8"			
		SUCTION - ϕ 200				DELIVERY - ϕ 150											

REV	DESCRIPTION	DRN	CHKD	DATE

FISHER PUMP

TITLE: **GA DRG. FOR 6HFTD12S**

DRG. NO. PSF/6HFTD12S/GA-01

SCALE: 1:1

REV: 0

