

PUMP MODEL- 8HF15

GENERAL ARRANGEMENT DRAWING FOR SINGLE STAGE AXIALLY SPLIT CASE PUMP MODEL - 8HF15

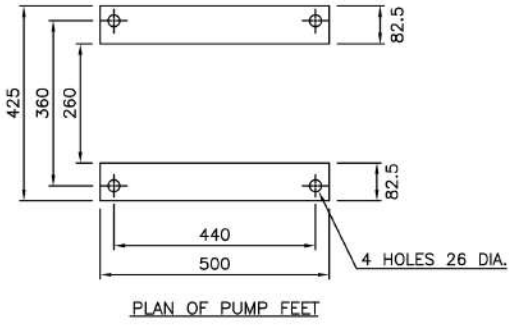
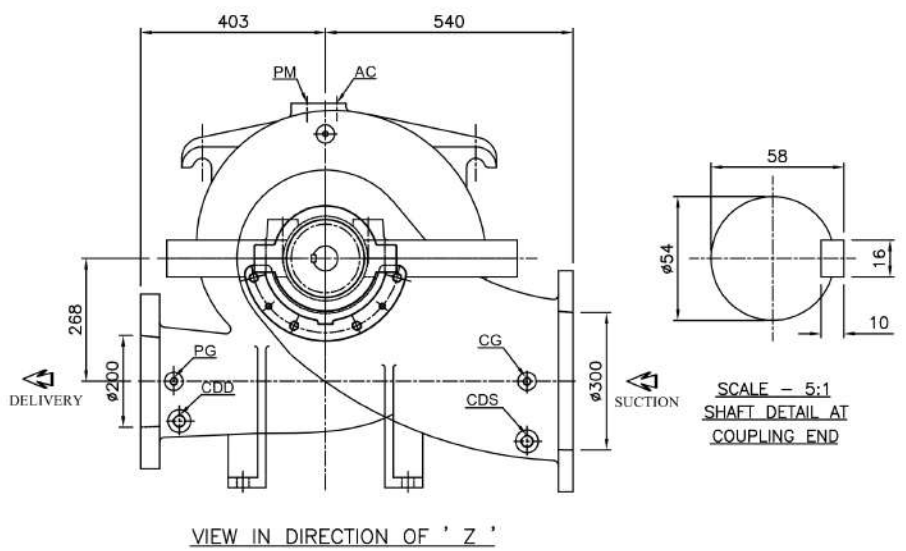
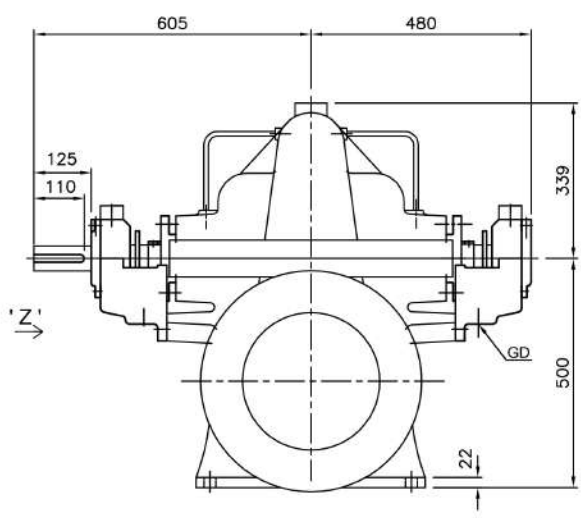

APPROX. NET WEIGHT -726 kg.
ALL DIMENSIONS ARE IN MM.

FISHER PUMP

CONNECTIONS		
ITEM	DESCRIPTION	SIZE(NPT)
GD	GLAND DRAIN	3/4"
CG	COMPOUND GAUGE FOR SUCTION	3/8"
PG	PRESSURE GAUGE FOR DELIVERY	3/8"
AC	AIR COCK	3/8"
PM	PRIMING	1"
CDS	CASING DRAIN(SUCTION SIDE)	3/4"
CDD	CASING DRAIN(DELIVERY SIDE)	3/4"

S	ANSI 250#FF	20-1/2"	17-3/4"	2"	16, Ø1-1/4"	-	-	15"	13"	1-5/8"	12, Ø1"	-	-	TITLE-		 SCALE 1:1		
D	ANSI 250#FF													GA DRAWING FOR 8HF15				
REF. NO.	TYPE OF FLANGE.	O.D.	P.C.D.	THK MIN	NO. SIZE OF HOLE	RF Ø	RF THK R.F. FLANGE	O.D.	P.C.D.	THK MIN	NO. SIZE OF HOLE	RF Ø	RF THK R.F. FLANGE	DRN	AD	03.08.17	DRG. NO. PSF/8HF15/GA-01	REV
		SUCTION 300 DIA.				DELIVERY 200 DIA				REV	DESCRIPTION		DRN	CHKD	APPD	HS		03.08.17