

PUMP MODEL - 8HF22

GENERAL ARRANGEMENT DRAWING FOR SINGLE STAGE AXIALLY SPLIT CASE PUMP MODEL - 8HF22

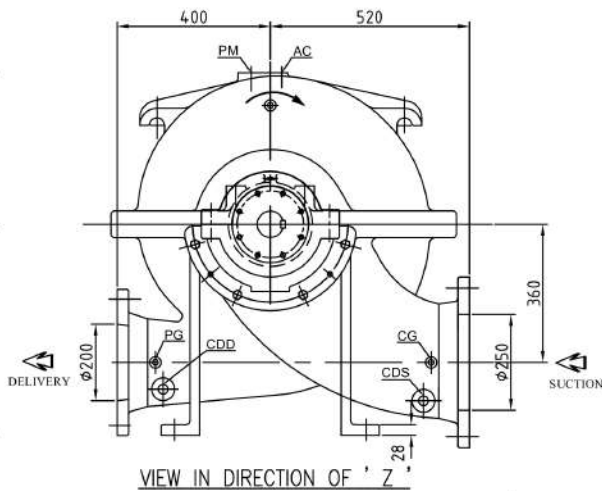

CLOCK-WISE ROTATION
LOOKING FROM DRIVE END

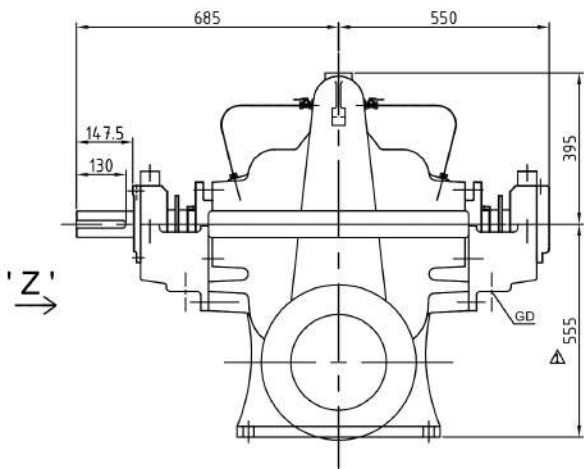
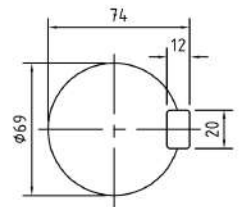

SCALE - 5:1
SHAFT DETAIL AT
COUPLING END

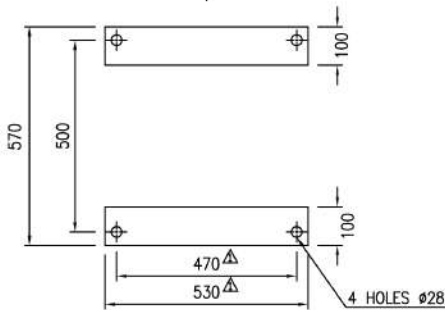

PLAN OF PUMP FEET

APPROX. NET WEIGHT - 900kg.
ALL DIMENSIONS ARE IN MM.

FISHER PUMP

CONNECTIONS		
ITEM	DESCRIPTION	SIZE(NPT)
GD	GLAND DRAIN	1"
CG	COMPOUND GAUGE FOR SUCTION	3/8"
PG	PRESSURE GAUGE FOR DELIVERY	3/8"
AC	AIR COCK	3/8"
PM	PRIMING	1-1/2"
CDS	CASING DRAIN(SUCTION SIDE)	1"
CDD	CASING DRAIN(DELIVERY SIDE)	1"

** GAUGE CONNECTIONS DRILLED AND TAPPED ONLY WHEN SPECIFICALLY REQUESTED BY THE CUSTOMER.

PROJECT NAME- _____ JOB NO.- _____

TITLE		SCALE 1:1
GA DRG. FOR 8HF22		
DRN	ST	DRG. NO. PSF/8HF22/GA-01/1
CHKD	SP	
APPD	HS	
REV		REV
DESCRIPTION		1

1	DIMENSION 555,470 & 530mm PREVIOUSLY IT WAS 530,455 & 520mm RESPECTIVELY DIMENSION CHANGED FOR STANDARDIZE SPLIT CASE GROUP 4 MODELS.	AD	ST	10.09.17
REV	DESCRIPTION	DRN	CHKD	DATE

S	ANSI 125FF	16'	4-1/4'	1-3/16'	12 Ø1'										
D	ANSI 250FF					15'	13'	1-5/8"	12 Ø1'						
REF. NO.	TYPE OF FLANGE	D.D.	P.C.D.	THK MIN	NO SIZE OF HOLE	RF Ø	RF THK	RF FLANGE	D.D.	P.C.D.	THK MIN	NO. SIZE OF HOLE	RF Ø	RF THK	RF FLANGE
		SUCTION 250 (10") I.D.						DELIVERY 200 (8") I.D.							