

PUMP MODEL - 8HF20

GENERAL ARRANGEMENT DRAWING FOR SINGLE STAGE AXIALLY SPLIT CASE PUMP MODEL - 8HF20

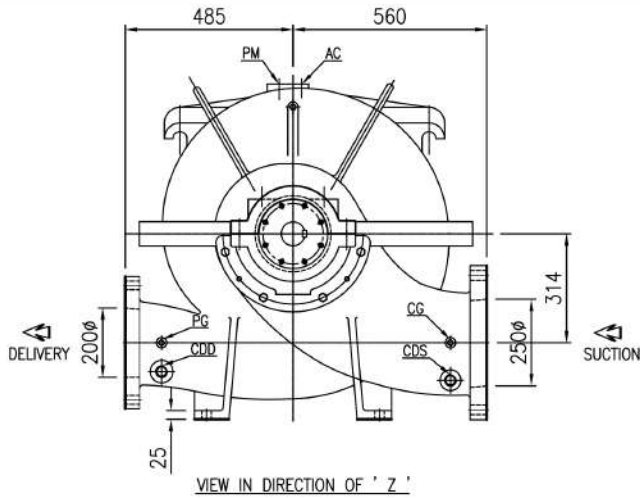

CLOCK-WISE ROTATION  
LOOKING FROM DRIVE END

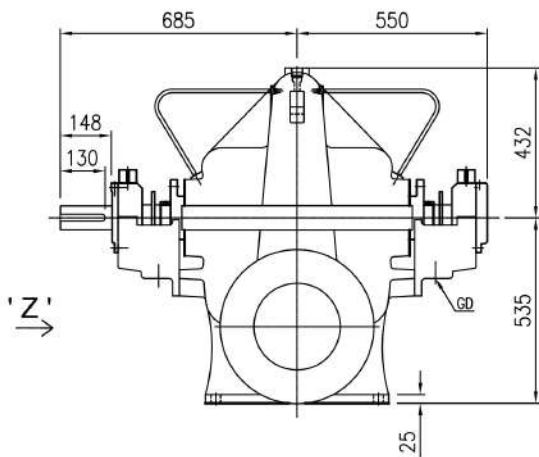
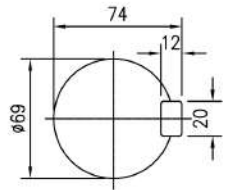

SCALE - 5:1  
SHAFT DETAIL AT  
COUPLING END

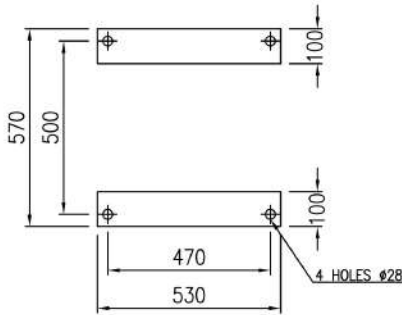

PLAN OF PUMP FEET

APPROX. NET WEIGHT - 860kg.  
ALL DIMENSIONS ARE IN MM.

**FISHER PUMP**

CONNECTIONS		
ITEM	DESCRIPTION	SIZE(NPT)
GD	GLAND DRAIN	1"
CG	COMPOUND GAUGE FOR SUCTION	3/8"
PG	PRESSURE GAUGE FOR DELIVERY	3/8"
AC	AIR COCK	3/8"
PM	PRIMING	1-1/2"
CDS	CASING DRAIN(SUCTION SIDE)	1"
CDD	CASING DRAIN(DELIVERY SIDE)	1"

\*\* GAUGE CONNECTIONS BLENDED AND TAPPED ONLY  
STAIN RESISTANT MATERIALS BY THE CUSTOMER

PROJECT NAME-		JOB NO.-	
TITLE-			
GA DRG. FOR 8HF20			
DRN AD 18.09.19		DRG. NO.	
CHKD TK 18.09.19		831GA10Y	
APPD BS 18.09.19		SCALE	
		1:1	
		REV	
		0	

S	ANSI#250	17-1/2"	15-1/4"	1-7/8"	16, Ø1-1/8"										
D	ANSI#250							15"	13"	1-5/8"	12, Ø1"				
REF. NO.	TYPE OF FLANGE.	O.D.	P.C.D.	THK MIN	NO SIZE OF HOLE OFF C/L	RFØ	RF THK R.F. FLANGE	O.D.	P.C.D.	THK MIN	NO SIZE OF HOLE OFF C/L	RFØ	RF THK R.F. FLANGE		
		SUCTION - Ø250				DELIVERY - Ø200									

REV	DESCRIPTION	DRN	CHKD	DATE