

PUMP MODEL- 6HFTD18

GENERAL ARRANGEMENT DRAWING FOR TWO STAGE AXIALLY SPLIT-CASE PUMP MODEL - 6HFTD18

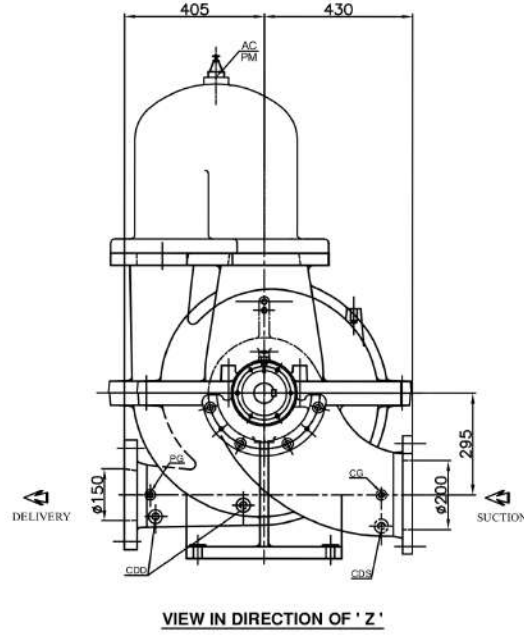

CLOCK WISE ROTATION
LOOKING FROM DRIVE END

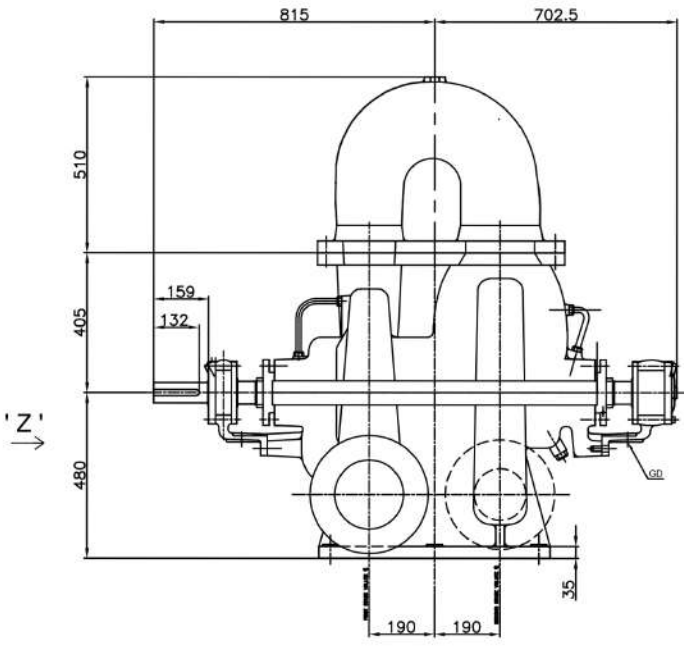
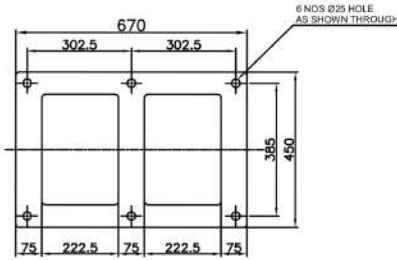
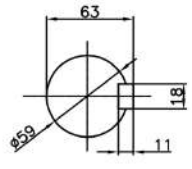

PLAN OF PUMP FEET

APPROX. NETT WEIGHT - 1206kg.
ALL DIMENSIONS ARE IN MM.

CONNECTION		
ITEM	DESCRIPTION	SIZE(NPT)
GD	GLAND DRAIN	3/4"
CG	COMPOUND GAUGE FOR SUCTION	3/8"
PG	PRESSURE GAUGE FOR DELIVERY	3/8"
AC	AIR COCK	3/8"
PM	PRIMING	3/4"
CDS	CASING DRAIN(SUCTION SIDE)	1/2"
CDD	CASING DRAIN(DELIVERY SIDE)	1/2"

S	ANSI#125	3-1/2"	11-3/4"	1-1/8"	8,7/8"	—	—								
D	ANSI#250							12-1/2"	10-5/8"	1-7/16"	12,7/8"	—	—		
REF. NO.	TYPE OF FLANGE	O.D.	P.C.D	THK MIN	NO. SIZE OF HOLE	RF	ØRF.THK RF FLANGE	O.D.	P.C.D	THK MIN	NO. SIZE OF HOLE	RF	ØRF.THK RF FLANGE		
		SUCTION - 200						DELIVERY - 150							
								REV	DESCRIPTION						

FISHER PUMP

TITLE- **GA DRG. FOR 6HFTD18**

SCALE 1:1

DRN	SF	28.11.16	DRG. NO.	9103530
CHKD	SF	28.11.16		
APPD	HS	28.11.16	910GA10Y	

REV 0