

PUMP MODEL - 4HF10

GENERAL ARRANGEMENT DRAWING FOR SINGLE STAGE AXIALLY SPLIT CASE PUMP MODEL - 4HF10

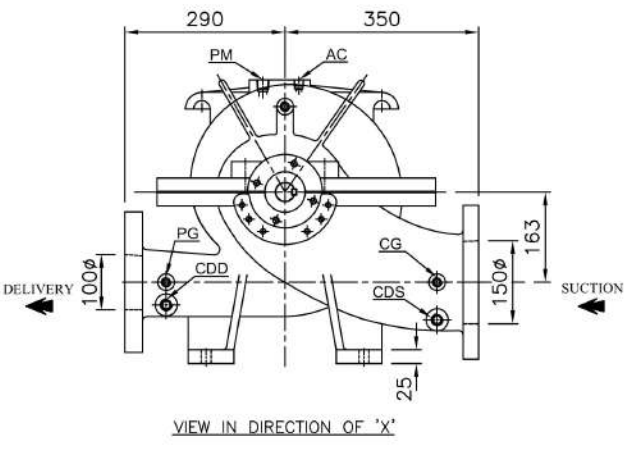

CLOCK-WISE ROTATION
LOOKING FROM DRIVE END

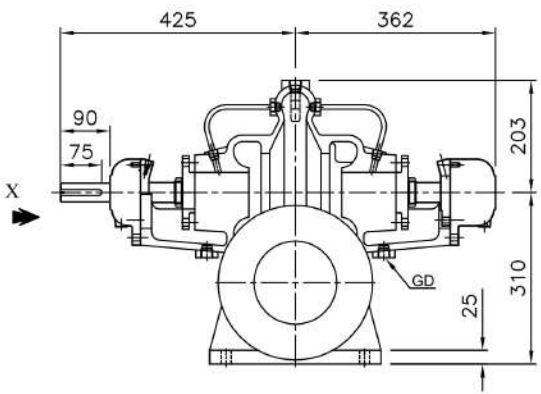
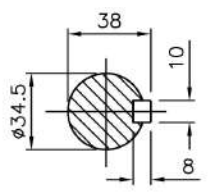

SCALE - 4:1
SHAFT DETAIL AT
COUPLING END

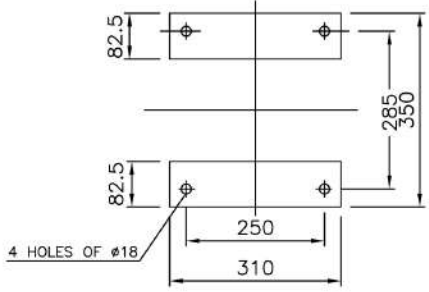

PLAN OF PUMP FEET

ALL DIMENSIONS ARE IN MM.
APPROX. NETT WEIGHT - 205kg.

CONNECTIONS		
ITEM	DESCRIPTION	SIZE (NPT)
GD	GLAND DRAIN	1/2"
CG	COMP. GAUGE FOR SUCTION	3/8"
PG	PR. GAUGE FOR DELIVERY	3/8"
AC	AIR COCK	3/8"
PM	PRIMING	1/2"
CDS	CASING DRAIN (SUCT.SIDE)	1/2"
CDD	CASING DRAIN (DELY.SIDE)	1/2"

FLANGE TABLE

S	ANSI 125#FF	11"	9-1/2"	1"	8, #7/8"												
D	ANSI 250#FF						10"	7-7/8"	1-1/4"	8, #7/8"							
REF. NO.	TYPE OF FLANGE	O.D.	P.C.D.	THK MIN	NO. SIZE OF HOLE	RF	ØRF. THK RF FLANGE	O.D.	P.C.D.	THK MIN	NO. SIZE OF HOLE	RF	ØRF. THK RF FLANGE				
		SUCTION - 150(6")				DELIVERY - 100(4")											

FISHER PUMP										
TITLE- GA DRAWING FOR 4HF10										
DRN	AD	18.05.20	DRG. NO.							SCALE
CHKD	SP	18.05.20	PSF/4HF10/GA-01/0							1:1
APPD	HS	18.05.20								REV
										0
REV	DESCRIPTION	DRN	CHKD	APPD	HS					