

PUMP MODEL - 6HF20

GENERAL ARRANGEMENT DRAWING FOR SINGLE STAGE AXIALLY SPLIT CASE PUMP MODEL - 6HF20

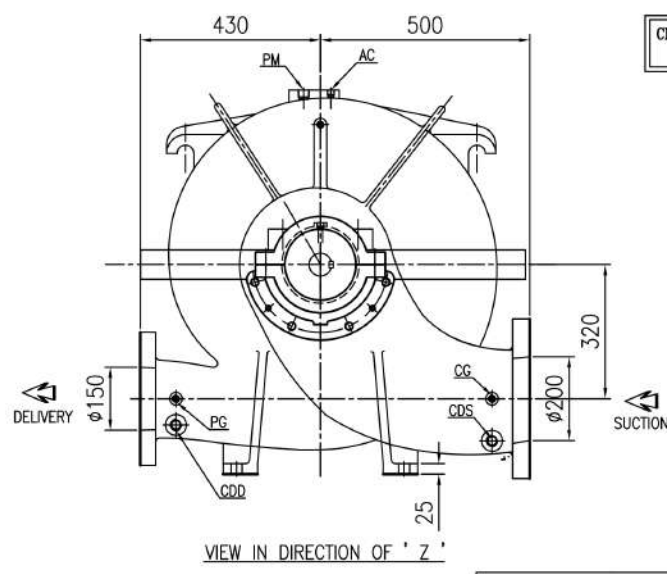

CLOCK-WISE ROTATION
LOOKING FROM DRIVE END

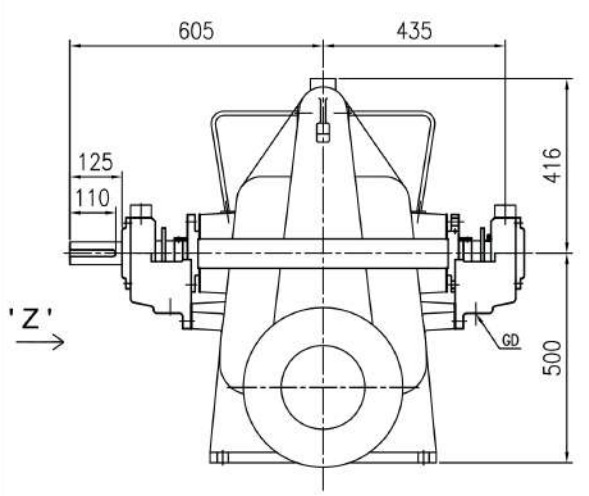
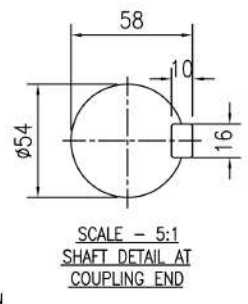

SCALE - 5:1
SHAFT DETAIL AT
COUPLING END

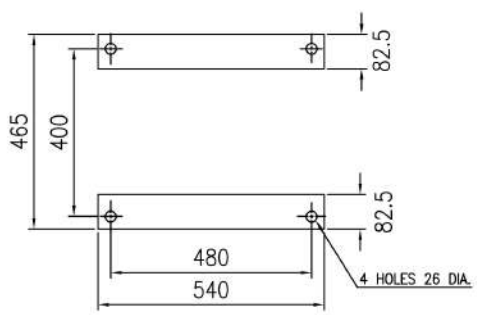

PLAN OF PUMP FEET

APPROX. NET WEIGHT - 751kg.
ALL DIMENSIONS ARE IN MM.

CONNECTIONS		
ITEM	DESCRIPTION	SIZE(NPT)
GD	GLAND DRAIN	3/4"
CG	COMPOUND GAUGE FOR SUCTION	3/8"
PG	PRESSURE GAUGE FOR DELIVERY	3/8"
AC	AIR COCK	3/8"
PM	PRIMING	1"
CDS	CASING DRAIN(SUCTION SIDE)	3/4"
CDD	CASING DRAIN(DELIVERY SIDE)	3/4"

** GAUGE CONNECTIONS DRILLED AND TAPPED ONLY
WHEN SPECIFICALLY REQUESTED BY THE CUSTOMER

DEL 150Ø	ANSI 250#FF	12-1/2"	10-5/8"	1-7/16"	12.Ø7/8"	---	---
SUC 200Ø	ANSI 250#FF	15"	13"	1-5/8"	12.Ø1"	---	---
	TYPE OF FLANGE	O.D.	P.C.D.	THK MIN	NO & HOLE Ø	RFØ	RF THK
						RF FLANGE	

				FISHER PUMP		
				TITLE- GA DRG. FOR 6HF20		
DRN	AD	16.09.19	DRG. NO.			REV 0
CHKD	SP	16.09.19	PSF/6HF20/GA-01			
APPD	HS	17.09.19				
REV	DESCRIPTION	DRN	CHKD	DATE		