

PUMP MODEL- 6HFTD18

GENERAL ARRANGEMENT DRAWING FOR TWO STAGE AXIALLY SPLIT-CASE PUMP MODEL - 6HFTD18

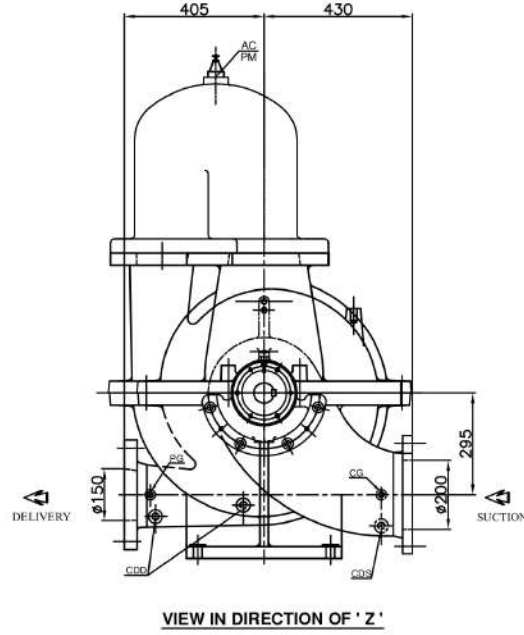

CLOCK WISE ROTATION
LOOKING FROM DRIVE END

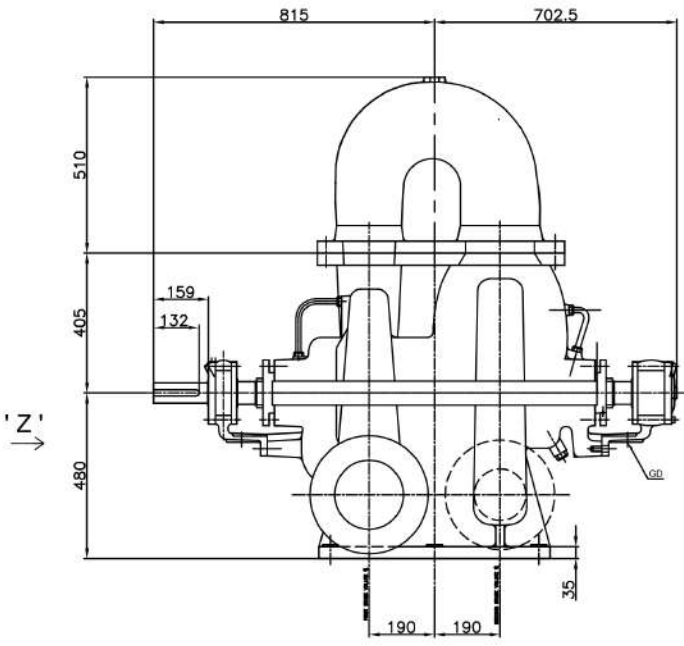
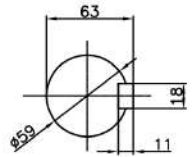

SCALE-4:1
SHAFT DETAILS
AT COUPLING END

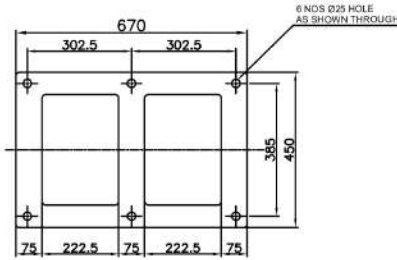

PLAN OF PUMP FEET

APPROX. NETT WEIGHT - 1206kg.
ALL DIMENSIONS ARE IN MM.

CONNECTION		
ITEM	DESCRIPTION	SIZE(NPT)
GD	GLAND DRAIN	3/4"
CG	COMPOUND GAUGE FOR SUCTION	3/8"
PG	PRESSURE GAUGE FOR DELIVERY	3/8"
AC	AIR COCK	3/8"
PM	PRIMING	3/4"
CDS	CASING DRAIN(SUCTION SIDE)	1/2"
CDD	CASING DRAIN(DELIVERY SIDE)	1/2"

S	ANSI#125	3-1/2"	11-3/4"	1-1/8"	8,7/8"												
D	ANSI#250							12-1/2"	10-5/8"	1-7/16"	12,7/8"						
REF. NO.	TYPE OF FLANGE	O.D.	P.C.D	THK MIN	NO. SIZE OF HOLE	RF	Ø RF. THK RF FLANGE	O.D.	P.C.D	THK MIN	NO. SIZE OF HOLE	RF	Ø RF. THK RF FLANGE				
		SUCTION - 200				DELIVERY - 150								REV	DESCRIPTION		

FISHER PUMP						
TITLE- GA DRG. FOR 6HFTD18						
DRN	ST	28.11.16	DRG. NO. 910GA10Y	9103530	SCALE	1:1
CHKD	ST	28.11.16			REV	0
APPD	HS	28.11.16				