

PUMP MODEL- 6HFTD12L

GENERAL ARRANGEMENT DRAWING FOR TWO STAGE AXIALLY SPLIT-CASE PUMP MODEL - 6HFTD12L

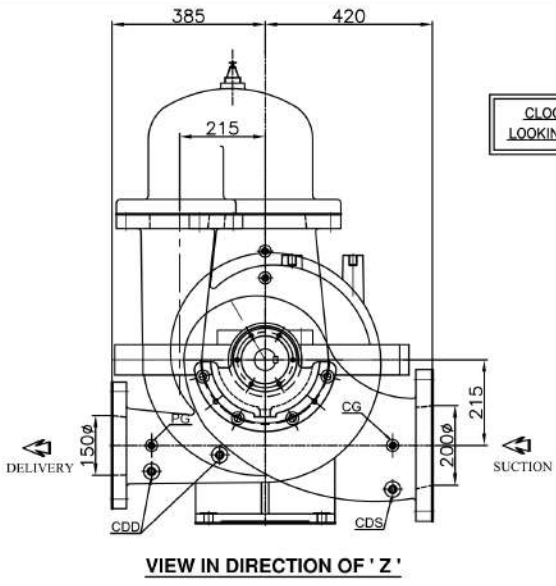

CLOCK WISE ROTATION
LOOKING FROM DRIVE END

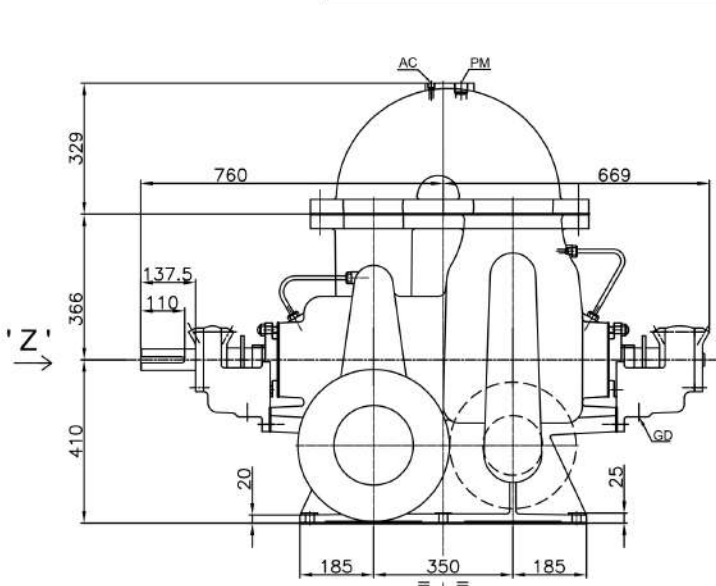
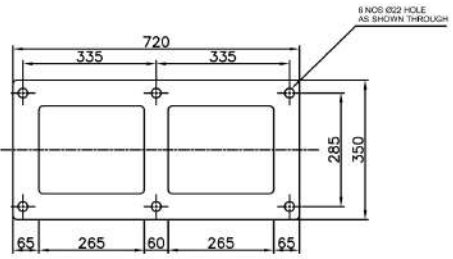
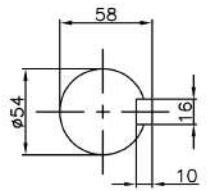

PLAN OF PUMP FEET

APPROX. NETT WEIGHT - 970kg.
ALL DIMENSIONS ARE IN MM.

CONNECTIONS		
ITEM	DESCRIPTION	SIZE(NPT)
GD	GLAND DRAIN	3/4"
CG	COMPOUND GAUGE FOR SUCTION	3/8"
PG	PRESSURE GAUGE FOR DELIVERY	3/8"
AC	AIR COCK	3/8"
PM	PRIMING	1"
CDS	CASING DRAIN(SUCTION SIDE)	1/2"
CDD	CASING DRAIN(DELIVERY SIDE)	1/2"

DEL 150Ø	ANSI 250#FF	12-1/2"	10-5/8"	1-7/16"	12,Ø7/8"	---	---
SUC 200Ø	ANSI 250#FF	15"	13"	1-5/8"	12,Ø1"	---	---
	TYPE OF FLANGE	O.D.	P.C.D.	THK MIN	NO & HOLE Ø	RFØ	RF THK
						RF FLANGE	

FISHER PUMP								SCALE 1:1
TITLE- GA DRG. FOR 6HFTD12L								
DRN	AD	17.06.19	DRG. NO.					REV 0
CHKD	ST	17.06.19	PSF/6HFTD12L/GA-01					
APPD	HS	17.06.19						
REV	DESCRIPTION	DRN	CHKD	DATE	APPD	HS	DRG. NO.	REV