

PUMP MODEL - 5HF10H

GENERAL ARRANGEMENT DRAWING FOR SINGLE STAGE AXIALLY SPLIT CASE PUMP MODEL - 5HF10H

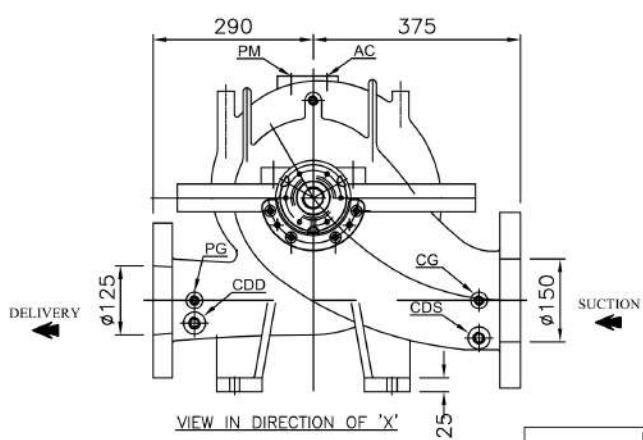

CLOCK-WISE ROTATION  
LOOKING FROM DRIVE END

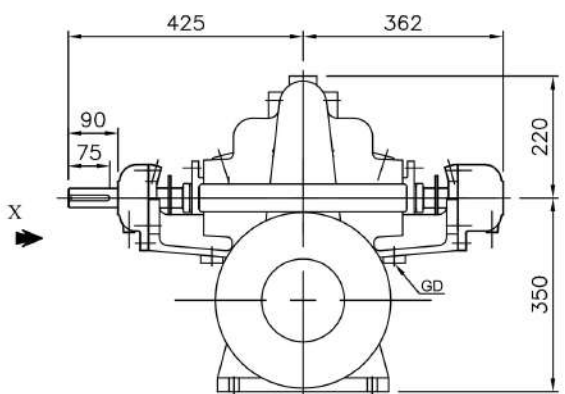
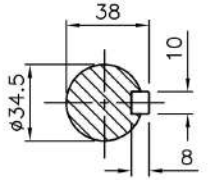

SCALE - 4:1  
SHAFT DETAIL AT  
COUPLING END

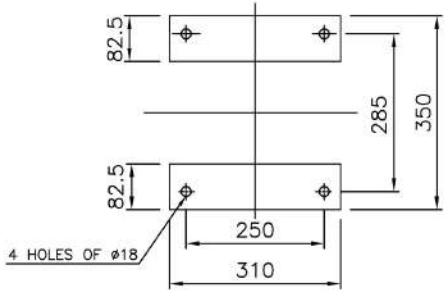

PLAN OF PUMP FEET

ALL DIMENSIONS ARE IN MM.  
APPROX. NETT WEIGHT - 255 kg.

CONNECTIONS		
ITEM	DESCRIPTION	SIZE (NPT)
GD	GLAND DRAIN	1/2"
CG	COMP. GAUGE FOR SUCTION	3/8"
PG	PR. GAUGE FOR DELIVERY	3/8"
AC	AIR COCK	3/8"
PM	PRIMING	1/2"
CDS	CASING DRAIN (SUCT.SIDE)	1/2"
CDD	CASING DRAIN (DELY.SIDE)	1/2"

NOTES:

1. AN ARROW MARK WILL BE ON THE TOP HALF OF THE CASING TO INDICATE THE DIRECTION OF ROTATION
2. COMPOUND GAUGE, DISCHARGE GAUGE, AIR RELEASE VALVE, CIRCULATION RELIEF VALVE (FOR MOTOR ONLY) WILL BE SUPPLIED WITH UL LISTED PUMP

FLANGE STD. - ANSI/ASME B16.1

SUC	ANSI250#	FF	O.D.	P.C.D.	THK MIN	NO & HOLE Ø	RFØ	RF THK	RF FLANGE
150	ANSI250#	FF	12-1/2"	10-5/8"	1-7/16"	12, Ø7/8"	---	---	---
125	ANSI250#	FF	11"	9-1/4"	1-3/8"	8, Ø7/8"	---	---	---

				<b>FISHER PUMP</b>			
				TITLE-			
				GA DRAWING FOR 5HF10H			REV 0
REV	DESCRIPTION	DRN	CHKD	APPD	HS	DRG. NO. 847GA10YJ	